



**HYDRAULIC LEVELING
WITH LCD TOUCHPAD
(4 POINT/3 VALVE MOTORIZED)
OWNER'S MANUAL**

**L I P P E R T
C O M P O N E N T S[®]**

TABLE OF CONTENTS

Introduction	2
Component Description.....	3
Safety	3
Operation	4
Selecting A Site.....	5
Automatic Leveling Procedure.....	5
Automatic Leveling Descriptive Logic.....	5
Manual Leveling Procedure.....	6
Automatic Jack Retract Procedures.....	6
Manual Jack Retract Procedures.....	7
Troubleshooting	7
Manual Override of The Power System and Jacks.....	7
Automatic Safety Shutoff.....	8
Drive-Away Protection System.....	8
Jacks Up Verification.....	8
Error Mode.....	9
Excess Slope.....	9
User Alarm Mode.....	9
Miscellaneous.....	9
Low Voltage Signal.....	10
Troubleshooting Table.....	10
Zero Point Calibration.....	11
Maintenance	11
Fluid Recommendation.....	11
Purging the Hydraulic System.....	12
Preventative Maintenance.....	12
Wiring Diagram (Non-Water Resistant)	13
Wiring Diagram (Water Resistant)	14
Hydraulic Plumbing Diagram (Aluminum Jacks)	15
Hydraulic Plumbing Diagram (Steel Jacks)	16
Notes	17

Introduction

The four-point three-valve hydraulic leveling system is a hydraulic system which includes four points of contact utilizing either steel or aluminum jacks, and a three-valve manifold system. A 12V DC electric motor drives a hydraulic pump that moves fluid through a system of hoses, fittings and jacks, to level and stabilize the coach. Mechanical portions of the hydraulic leveling system are replaceable. Contact Lippert Components, Inc. to obtain replacement parts.

The hydraulic leveling system is primed and tested at the factory. However, the system is shipped dry to avoid hazardous material restrictions.

NOTE: This manual replaces the following previously released LCI manuals: Class C Hydraulic Leveling Owner's Manual (CCD-0001514) dated 07.19.18 and Class C Hydraulic Leveling (Weld-on) Owner's Manual (CCD-0001487) dated 06.20.18. These two manuals were consolidated into this manual.

For information on the assembly or individual components of this product, please visit:

<https://support.lci1.com/hydraulic-leveling-lcd-br4-point3-valve>

Component Description

1. Jacks
 - A. 5K steel or 8K aluminum
 - B. Rated at a lifting capacity for the coach
 - C. Standard 9-inch diameter (63.5 square inch) footpad on a ball swivel for maximum surface contact on all surfaces
 - D. Operational powered from a 12V DC motor/pump assembly
2. Motor/Pump Assembly
 - A. 12V DC motor
 - B. Hydraulic fluid reservoir tank
 - C. Control valve manifold
 - D. Solenoid valve
3. System Controls
 - A. Controlled electronically from the touchpad
 - B. Touchpad can be operated in manual mode or fully automatic mode
4. Fittings and Hoses
 - A. Fittings - High pressure O-Ring Face or J.I.C. - Size 4
 - B. Hose - 1/4" I.D., 3000 psi - W.P. Rated

Safety

Please read and study the operating manual before operating the leveling system.

WARNING

The "WARNING" symbol above is a sign that a procedure has a safety risk involved and may cause death or serious personal injury if not performed safely and within the parameters set forth in this manual.

WARNING

During servicing make sure that the coach is supported according to the manufacturer's recommendation. Lift the coach by the frame and never the axle or suspension. Do not go under the coach unless it is properly supported. Unsupported coaches can fall causing death or personal injury or product or property damage.

WARNING

Failure to act in accordance with the following may result in serious personal injury or death.

CAUTION

The "CAUTION" symbol above is a sign that a safety risk is involved and may cause personal injury and/or product or property damage if not safely adhered to and within the parameters set forth in this manual.

CAUTION

Moving parts can pinch, crush, or cut. Keep clear and use caution

The use of the Lippert Components, Inc. Hydraulic Leveling System to support the coach for any reason other than which it is intended, is prohibited by the Lippert Limited Warranty. The Hydraulic Leveling System is designed as a leveling system only and should not be used for any reason to provide service under the coach, e.g. changing tires or servicing the leveling system.

Lippert Components, Inc. recommends that a trained professional be employed to change the tires on the coach. Any attempts to change tires or perform other service while the coach is supported by the hydraulic leveling system could result in damage to the coach and/or cause serious injury or death.

Operation

NOTE: It is recommended that the engine idle to maintain the minimum required voltage of 12.75V DC.

The leveling system should only be operated under the following conditions:

1. The coach is parked on a reasonably level surface.
2. The coach parking brake is engaged.
3. The coach transmission should be in the park position.
4. Make sure all people, pets and property are clear of the coach while the hydraulic leveling system is in operation.

⚠ CAUTION

After starting the automatic leveling cycle it is very important to not move around in the coach until the coach is level and the green LED light illuminates in the center of the touchpad. Failure to remain still during the leveling cycle could have an effect on the performance of the leveling system.

Fig. 1

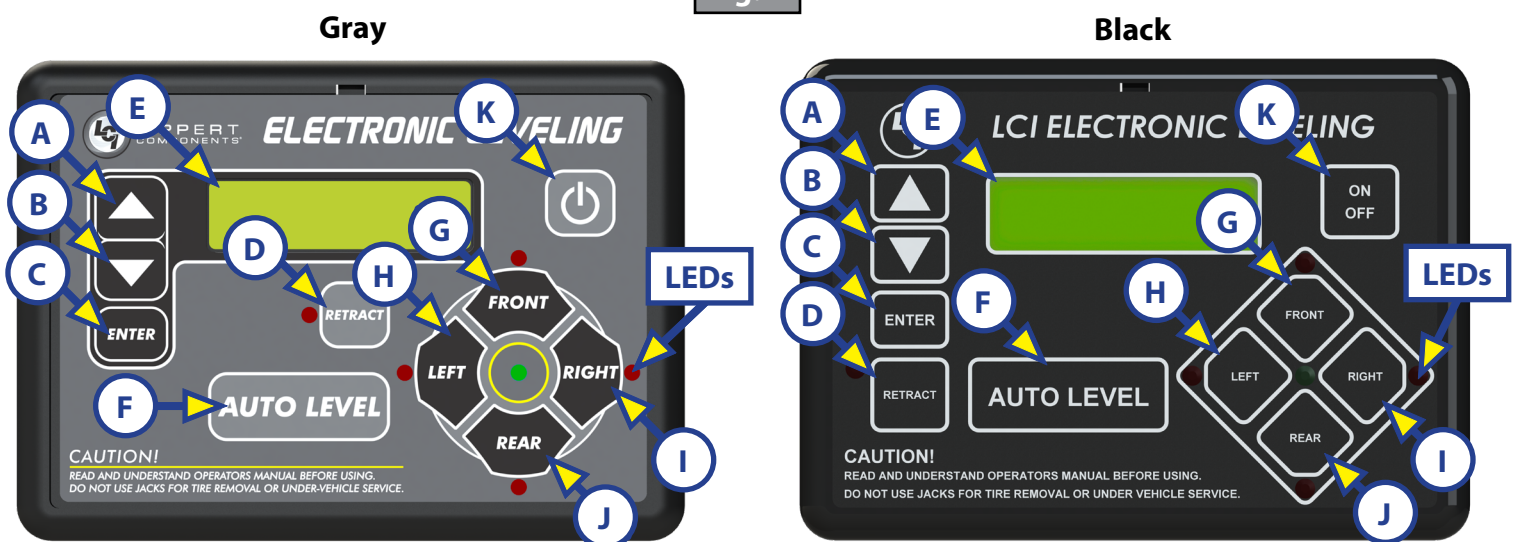

NOTE: Coaches manufactured before January 2018 will utilize the black touchpad.

Callout	Description
A	Up Arrow (UP) - Scrolls up through the menu on LCD.
B	Down Arrow (DOWN) - Scrolls down through the menu on LCD.
C	ENTER - Activates modes and procedures indicated on LCD.
D	RETRACT- Places leveling system into retract mode. — Manual mode ONLY Press and hold for several seconds to activate Auto Retract Function.
E	LCD Display - Displays procedures and results.
F	AUTO LEVEL - Places leveling system into auto level mode.
G	FRONT Jack Button - Activates both front jacks in manual mode.
H	LEFT Jack Button - Activates left rear jack in manual mode.
I	RIGHT Jack Button - Activates right rear jack in manual mode.
J	REAR Jack Button - Activates both rear jacks in manual mode.
K	Power Button - Turns leveling system on and off.

Selecting A Site

When the coach is parked on an excessive slope, the leveling requirements may exceed the jack lift stroke capability. If the coach is parked on an excessive slope, the coach should be moved to a more level surface before the leveling system is deployed. "EXCESS ANGLE" will appear on the LCD screen if the coach is 3.5 degrees out of level front-to-rear or side-to-side.

WARNING

While utilizing leveling blocks and jack pads, all coach wheels MUST not leave the ground during leveling. Lifting all the wheels off the ground creates a condition where severe property damage, serious personal injury or possible death may occur.

Automatic Leveling Procedure

NOTE: Coach requires 12.75V DC to commence auto-leveling function.

NOTE: Refer to Component Description listing in the System Information section for questions regarding component locations and functions of the hydraulic leveling system.

NOTE: The engine **MUST** be running and the parking brake **MUST** be engaged for the hydraulic leveling system to operate.

NOTE: Pressing any button during an automatic sequence will stop the sequence and a "Function Aborted" error code will occur. Press ENTER to clear the code and then continue the operation or start a new function.

1. Press Power Button to turn system on (Fig. 1K). The green light will illuminate.
2. Press AUTO LEVEL (Fig. 1F). LCD Screen will display "Remain Still."
3. The coach will level automatically and indicate "Auto Level - Success" in the LCD display (Fig. 1E).

NOTE: Display will then read "Level - Jacks: Down." Do not press any buttons until this message appears or a "Function Aborted" error will be displayed.

Automatic Leveling Descriptive Logic

Grounding: The following steps describe the process of how the auto-leveling sequence extends the jacks to the ground:

1. Depending on which end of the coach is lowest to the ground, the level sensor in the controller will activate the jacks — the lowest end first, either front or rear.
 - A. If the rear of the coach is the lowest end, ground the lowest rear jack first.
 - B. If the front end is the lowest end, ground the front jack closest to the power unit.
2. Ground the lowest remaining front or rear end jack.
3. Lift lowest end jacks together until level.
4. The leveling system will then ground remaining end jacks.
 - A. If the rear of the coach is the remaining end, ground lowest jack first.
 - B. If the front of the coach is the remaining end, ground the front jack closest to the power unit.
5. Ground the remaining front or rear remaining end jack.
6. Lift remaining end jacks together until level.

Leveling: The following steps describe the process of how the auto-leveling sequence levels the coach once the jacks have been grounded. This process may repeat several times until level.

1. Front-to-rear
2. Side-to-side
3. Individually
4. Minor adjustments to confirm grounding

Manual Leveling Procedure

NOTE: The coach should be leveled front-to-rear first and then leveled side-to-side.

NOTE: The engine **MUST** be running and the parking brake **MUST** be engaged for the hydraulic leveling system to operate.

NOTE: Performing manual leveling on a coach requires a minimum of 9.5V DC.

1. Press Power Button (Fig. 1K) to turn system on.
2. Press the Up Arrow (Up) or the Down Arrow (Down) (Fig. 1A or Fig. 1B) to scroll through control features until "Manual Mode" is displayed.
3. Press Enter (Fig. 1C).
4. Press Front (Fig. 1G) to extend front jacks to the ground.
5. Press Rear (Fig. 1J) to extend rear jacks to ground, then level the coach front-to-back.
6. Press appropriate Left or Right to level the coach side-to-side.

NOTE: Red lights next to the buttons on touchpad will indicate which side(s) of the coach needs to be raised to achieve level condition.

NOTE: The front jacks will work in pairs, i.e., FRONT operates both front jacks.

NOTE: The right and left rear jacks are used to level the coach side-to-side. Pressing LEFT (Fig. 1H) will extend the left rear jack. Pressing RIGHT (Fig. 1I) on the touchpad will extend the right rear jack.

7. Repeat steps 4-6 as needed.
8. Turn off power to leveling system by pressing the Power Button (Fig. 1K).
9. Visually inspect all jacks to make sure all footpads are touching the ground. If either of the rear jack footpads is not touching the ground, press LEFT or RIGHT (Fig. 1H or Fig. 1I) to lower the non-compliant jack to the ground.

Automatic Jack Retract Procedures

NOTE: Pressing any button during an automatic sequence will stop the sequence and a "Function Aborted" error code will occur. Press ENTER to clear the code and then continue the operation or start a new function.

1. Energize the system by pressing the Power Button (Fig. 1K) on the touchpad. The LCD screen will display "READY Jacks: Down."
2. Press Up Arrow (UP) or Down Arrow (DOWN) (Fig. 1A or Fig. 1B) to display "Auto Retract All" on the screen.
3. Press ENTER (Fig. 1C) to begin.

NOTE: "AUTO RETRACT" can also be commenced by pressing and holding RETRACT (Fig. 1D) for one second.

4. The jacks will retract and shut off automatically.
 - A. The display will read "READY - Jacks: Up."
 - B. Press the Power Button (Fig. 1K) on the touchpad to de-energize the system.
 - C. Perform a brief visual inspection around the coach to verify the jacks are fully retracted.

Manual Jack Retract Procedures

⚠ WARNING

All coach wheels MUST NOT leave the ground during leveling. Lifting all the wheels off of the ground creates a condition where severe property damage, serious personal injury or possible death may occur.

To retract in MANUAL mode, do as follows:

1. Press RETRACT (Fig. 1D) until green indicator light comes on.
2. Pressing FRONT or REAR (Fig. 1G or Fig. 1J) will operate the respective jacks in pairs.
3. Pressing RIGHT (Fig. 1I) will operate the right rear jack.
4. Pressing LEFT (Fig. 1H) will operate the left rear jack.

Troubleshooting

⚠ CAUTION

Make sure all jacks are fully retracted before travel.

Manual Override of The Power System and Jacks

In the event that the jacks do not retract, the cartridge valves can be manually overridden.

NOTE: Cartridge valves should be opened prior to operating with any auxiliary power device.

The hydraulic leveling system can be operated in conjunction with auxiliary power devices, like cordless or power drills. In the event of electrical or system failure, the manual method of retracting the jacks can be used. A standard handheld drill is all that is required.

⚠ CAUTION

Do not overtighten override set screws as this can damage the valves.

1. Use a $\frac{5}{32}$ " hex key to turn the manual override clockwise (Fig. 2) on each of the three cartridge valves to open the valves.
2. Disconnect or shield power cables on the motor.
3. Remove plastic cap (Fig. 3A) from motor coupler.
4. Unplug the wire harness from the directional valve. See Wiring Diagram.

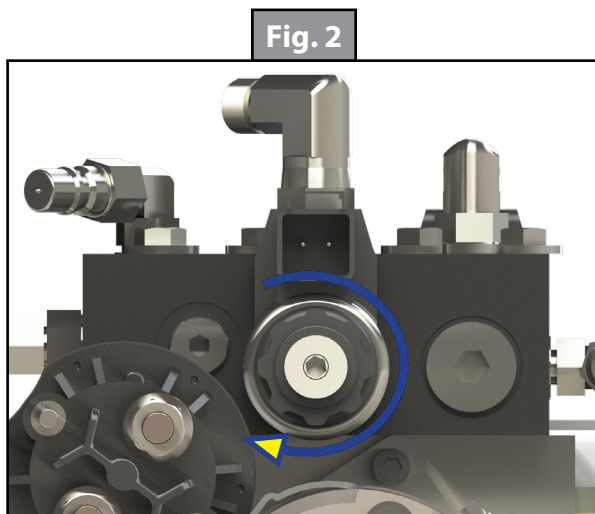

Clockwise for Manual Override

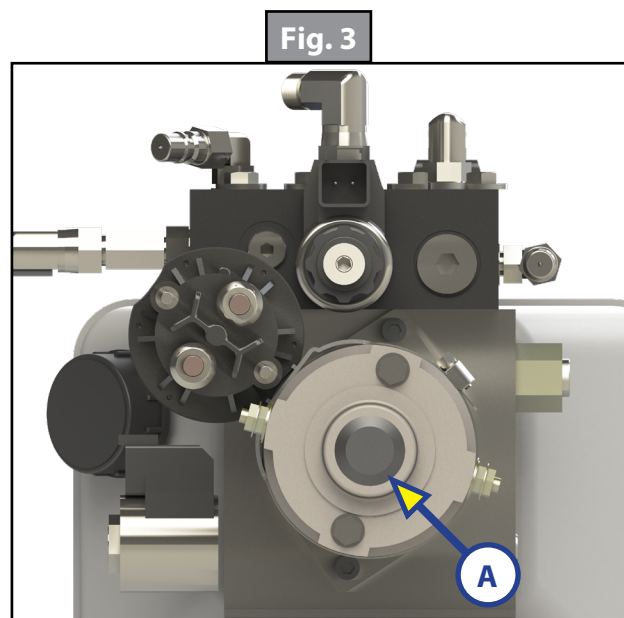

5. Using a 1/2" socket and auxiliary drive device, e.g. cordless or power drill, insert 1/2" socket onto coupler (Fig. 4A).
6. Run drill in reverse, or counterclockwise direction, to simultaneously retract all jacks.
7. After all jacks have been retracted, turn all manual overrides on the cartridge valves counterclockwise (Fig. 5).
8. Reinsert previously removed protective plastic motor coupler cap.
9. Re-attach previously unplugged wire harness to directional valve.

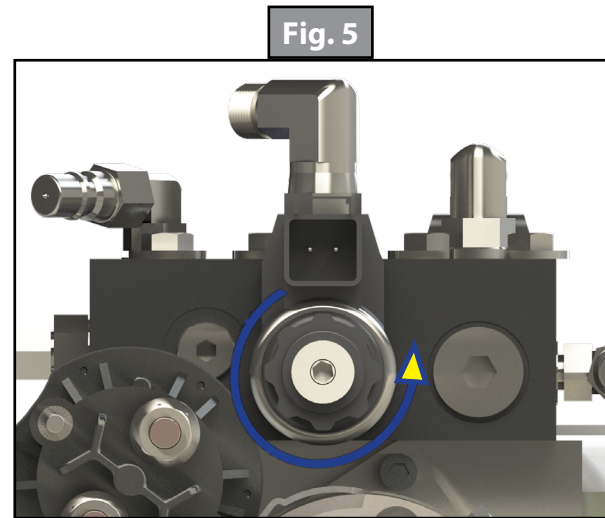
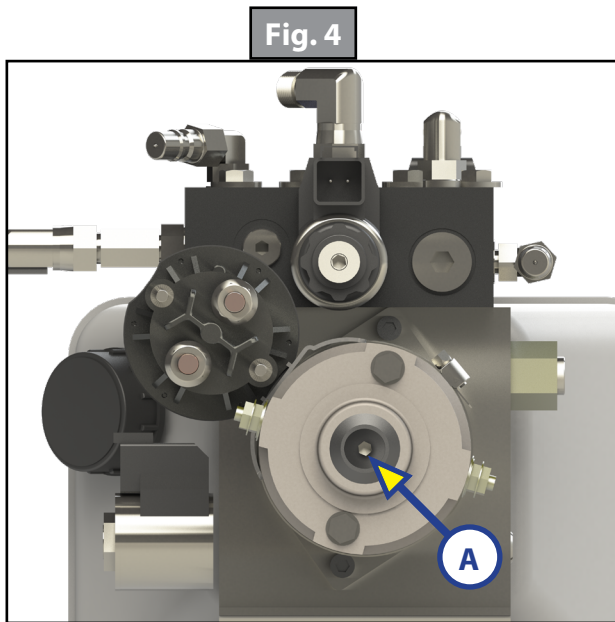

Counterclockwise for Normal Operation

Automatic Safety Shutoff

The touchpad will automatically shutoff after four minutes, if left inactive. To reset the system, turn the coach's ignition off, then back on. Press the touchpad's Power Button (Fig. 1K) again.

Drive-Away Protection System

If the ignition is in the "RUN" position, jacks are extended and the operator releases the parking brake, all indicator lights will flash and the alarm beeper will activate. The leveling system will automatically fully retract the jacks to clear the alarm or, if the operator resets the parking brake, the alarm will shut off.

Jacks Up Verification

If the coach's ignition is in the "RUN" position, the parking brake is released and the vehicle is in motion, the leveling system may activate the power unit to ensure retract pressure is high enough to keep jacks fully retracted. The LCD screen will say "JACKS UP VERIFICATION" until the retract pressure returns to normal level. The touchpad will shut off. No beeping will occur and the "JACKS DOWN" dash light will not illuminate.

Error Mode

1. If an error occurs before or during operation, the error will be displayed in the touchpad's LCD screen (Fig. 1E) and an alarm will sound. To reset common ERROR displays, press ENTER (Fig. 1C).
NOTE: To reset "Return for Service" errors, press ENTER (Fig. 1C) and RETRACT (Fig. 1D) simultaneously. Refer to Error Code Chart for additional error codes.
2. All normal functions will be disabled while the system is in Error Mode.

Error Code Chart		
LCD Display	What is Happening?	What Should Be Done?
Excess Angle	Coach not parked on level ground. Zero point incorrectly calibrated.	Move coach to level ground prior to starting auto level sequence. Recalibrate Zero Point.
Excessive Angle	Occurs only in manual mode when the angle of the coach is too severe.	Use the manual functions to return coach to a more level condition.
Out of Stroke	Jack has insufficient length to complete the leveling procedure.	Check the disposition of the jack.
Low Voltage	Battery voltage dropped below 9.5V DC during operation.	Turn engine on, check battery voltage under load.
Function Aborted	A button was pressed on touchpad during Auto Level operation.	Hit enter to acknowledge. Restart procedure.
Unable to Finish Leveling	Excessive movement inside coach during auto level sequence.	Discontinue movement inside coach during auto level sequence.
Engage Park Brake	Parking brake not set prior to starting auto level sequence.	Set parking brake prior to starting auto level sequence.
Comm Error Check Wiring NOTE: Screen will not back light.	Wiring connections loose or faulty between touchpad and controller.	Check connections, replace communication harness if necessary.
Retract Timeout Return Levelers for Service	Pressure switch did not sense retract pressure and pump timed out. Leaking hose or fitting.	Return levelers for service. Check for leaks, repair if necessary. Press enter and retract to clear error.

Excess Slope

1. The control will not operate at extreme slopes, i.e. 3.5 degrees front and rear and 3.5 degrees side-to-side.
2. If the coach's display indicates "Excess Angle" or "Out of Stroke " during an auto-level cycle, move the coach to a level spot.

User Alarm Mode

If the alarm system detects that the park brake has been disengaged while at least one jack is not fully retracted, the touchpad will buzz and the LED will signal a park break error to the user. The system will then perform an automatic retract sequence. No other features are available in this mode.

Miscellaneous

1. A "Re-Level" feature is programmed into the controller. If the jacks are extended and the user presses AUTO LEVEL (Fig.1F), the system will re-level from that point. The system will not retract before performing the re-level.
2. System will refuse any operation when a low voltage condition is present.

Low Voltage Signal

1. The vehicle requires 12.75V DC to operate in the AUTO mode. If the voltage is too low, the screen will display "Low Voltage."
2. Minimum Voltage - If voltage drops below 9.5V DC during AUTO or MANUAL operation, "Low Voltage" will appear in the screen and the system will cease operating.

NOTE: Coach will operate in manual mode between 9.5V DC and 12.75V DC.

Troubleshooting Table

What Is Happening?	Why?	What Should Be Done?
System will not turn on and the on/off indicator light does not illuminate.	Coach ignition is not in RUN position.	Turn ignition to RUN position.
	Touchpad has been on, but inactive for more than four minutes and has timed out.	Turn ignition OFF and then back ON.
Touchpad turns on, but turns off when jack directional buttons are pressed or touchpad displays "low voltage."	Tripped or blown circuit protection.	Reset or replace circuit protection.
	Low voltage on battery.	Start coach to charge battery.
Touchpad turns on, coach will not auto-level, "Jacks Down" displayed, jacks are retracted.	Low fluid level.	Check fluid level in reservoir. Fluid is low, with jacks retracted, add fluid to 1/2" from top of reservoir. If "Jacks Down" light remains on, call Lippert Customer Service.
Jacks will not extend to ground while pump is running.	Little or no fluid in reservoir.	Add fluid as recommended.
	Cartridge valve is inoperative.	Clean, repair, or replace cartridge valve.
	Electronic signal is lost between controller and coil.	Trace wires for voltage drop or loss, or no valve signals. Repair or replace necessary wires or replace control pad.
Any one or two jacks will not retract.	Hose damaged or unconnected.	Replace with new hose or reconnect hose.
	Cartridge valve is inoperative.	Replace inoperative cartridge valve.
	Electronic signal is lost between controller and coil.	Attempt to retract jacks in MANUAL mode. If successful, replace touchpad; if not, test for voltage drop between touchpad and coil, repair bad wiring or replace defective controller or cartridge valve.
"READY - Jacks: Up" does not display when all jacks are retracted.	Low fluid level.	Add fluid as recommended.
	Retract pressure switch inoperable.	Check connection or replace pressure switch.
Alarm sounds and "Jacks Down" light starts flashing while traveling; jacks are fully retracted.	Low fluid level.	Add fluid as recommended.
	Retract pressure switch inoperable.	Check connection or replace pressure switch.

What Is Happening?	Why?	What Should Be Done?
Coach bleeds down after jacks are extended. Jack bleeds down after being retracted.	Possible fluid leak.	Check for fluid leaks and repair or replace components as necessary.
	Cartridge valve manual override open.	Close override, see Manual Override of The Power System and Jacks.
Touchpad powers up; screen displays "low voltage."	Loose ground wire at power unit.	Check for loose wires.
	Engine not running.	Start coach engine.
No power to touchpad.	Tripped or blown circuit protection.	Reset or replace circuit protection.
	Ignition not ON.	Turn ignition ON.
Auto level function does not finish.	Error code "Unable to finish leveling."	Move coach to a level site.

Zero Point Calibration

Before auto leveling features are available, the Zero Point MUST be set. This is the reference point that the system will return to when an auto leveling cycle is initiated.

To set the Zero Point, first run a manual leveling sequence to get the coach to the desired level point. Then activate the Zero Point configuration mode. This mode is enabled by performing the following sequence:

1. Run a manual leveling sequence to set the trailer to the desired level point.
2. Activate the Zero Point configuration mode as follows:
 - A. Turn off touchpad.
 - B. Press FRONT button (Fig. 1G) 10 times.
 - C. Press REAR button (Fig. 1J) 10 times.

NOTE: An alarm will sound and the display will read ZERO POINT CALIBRATION; ENTER to set, Power to Exit (Fig. 6).

- D. Press ENTER (Fig. 1C) to set the Zero Point.
3. Screen will then display PLEASE WAIT.
4. An alarm will sound and the screen will display "Zero point set successfully" (Fig. 7).
5. The touchpad will then turn off.

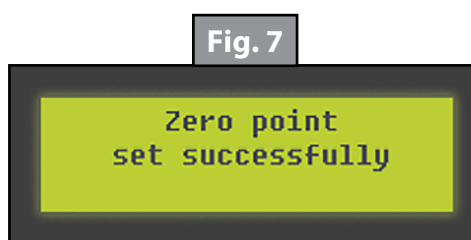
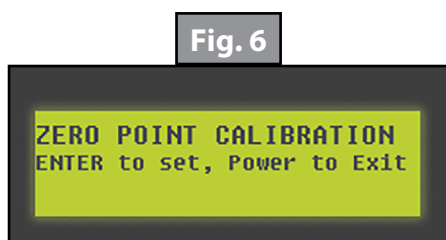

Maintenance

Fluid Recommendation

Automatic transmission fluid (ATF) with Dexron®III or Mercon®V or a blend of both is recommended by Lippert Components, Inc. For a list of approved fluid specifications, see [TI-188](#). To obtain this Technical Information sheet on-line, go to <http://www.lci1.com/support-lci4a3lcd>. Then click on the Technical Information Sheets tab. Look for TI-188: Hydraulic Operation Fluid Recommendation within the listing.

NOTE: In colder temperatures (less than 10 ° F) the jacks may extend and retract slowly due to the fluid's molecular nature. For cold weather operation, fluid specially formulated for low temperatures may be desirable.

WARNING

The coach should be supported at both front and rear axles with jack stands before working underneath. Failure to do so may result in death, serious personal injury or severe product or property damage.

Purging the Hydraulic System

NOTE: Make sure jacks are fully retracted prior to filling reservoir to prevent over-filling

1. Zip-tie any loose wiring or hydraulic lines.

NOTE: The basic purge procedure to bleed the LCI Hydraulic Systems can be performed without the use of any tools. The hydraulic system will purge the air from the hydraulic lines and cylinders by simply running the pump.

NOTE: It is recommended to perform a minimum of three complete cycles (steps 2-7) to ensure both proper function and adequate fluid level of the system.

2. Start with all hydraulic components in the fully retracted position, meaning all jacks and slide-outs are brought back inside the coach as if the coach were ready for travel.
3. Find the hydraulic pump location and note the amount of fluid currently in the reservoir. The fluid level should be about $\frac{1}{4}$ " from the top of the reservoir and no more than $\frac{1}{2}$ " from the top.

NOTE: When checking the fluid level after ensuring all hydraulic components are retracted, note if there are any bubbles, froth or foam on top of the fluid. This is an indication that air has been pushed back to the reservoir when the hydraulic components were retracted in the last cycle. Wait 15-20 minutes for the foam to dissipate before beginning the purge process.

4. If there is no froth or foam in the reservoir and the fluid is not within $\frac{1}{2}$ " of the top, fill the reservoir to within the level described in step 3.
5. With the fluid level full and no foam in the reservoir, begin cycling the hydraulic system.
6. Extend jacks fully, taking the coach off the tires. If the coach has hydraulic slide-outs, extend all slide-outs. Once all jacks and slide-outs are extended, immediately retract all slide-outs and then jacks.
7. Check the reservoir foam. If foam is present, see NOTE following step 3 and then repeat steps 4-6. Repeat these steps until no foam is present in the reservoir. If no foam is present, the system is purged of air.

Preventative Maintenance

1. Check hydraulic fluid in reservoir every 12 months. If fluid is a clear, red color, do not change. If fluid is milky, pink and murky, and not clear red in color, drain reservoir and add new fluid. Hydraulic fluid in reservoir should be changed a minimum of every five years.

NOTE: Check the hydraulic fluid only when all the jacks are fully retracted.

NOTE: When checking the hydraulic fluid level, fill reservoir to within $\frac{1}{4}$ " to $\frac{1}{2}$ " of fill spout.

2. Inspect and clean all power unit electrical connections every 12 months. If corrosion is evident, spray connections with electrical contact cleaner.
3. Remove dirt and road debris from jacks as needed.
4. If jacks are extended for long periods of time, it is recommended to spray exposed jack rods with a dry silicone lubricant every three months for protection. If the coach is located in a salty environment, it is recommended to spray the rods every four to six weeks.

Wiring Diagram (Non-Water Resistant)

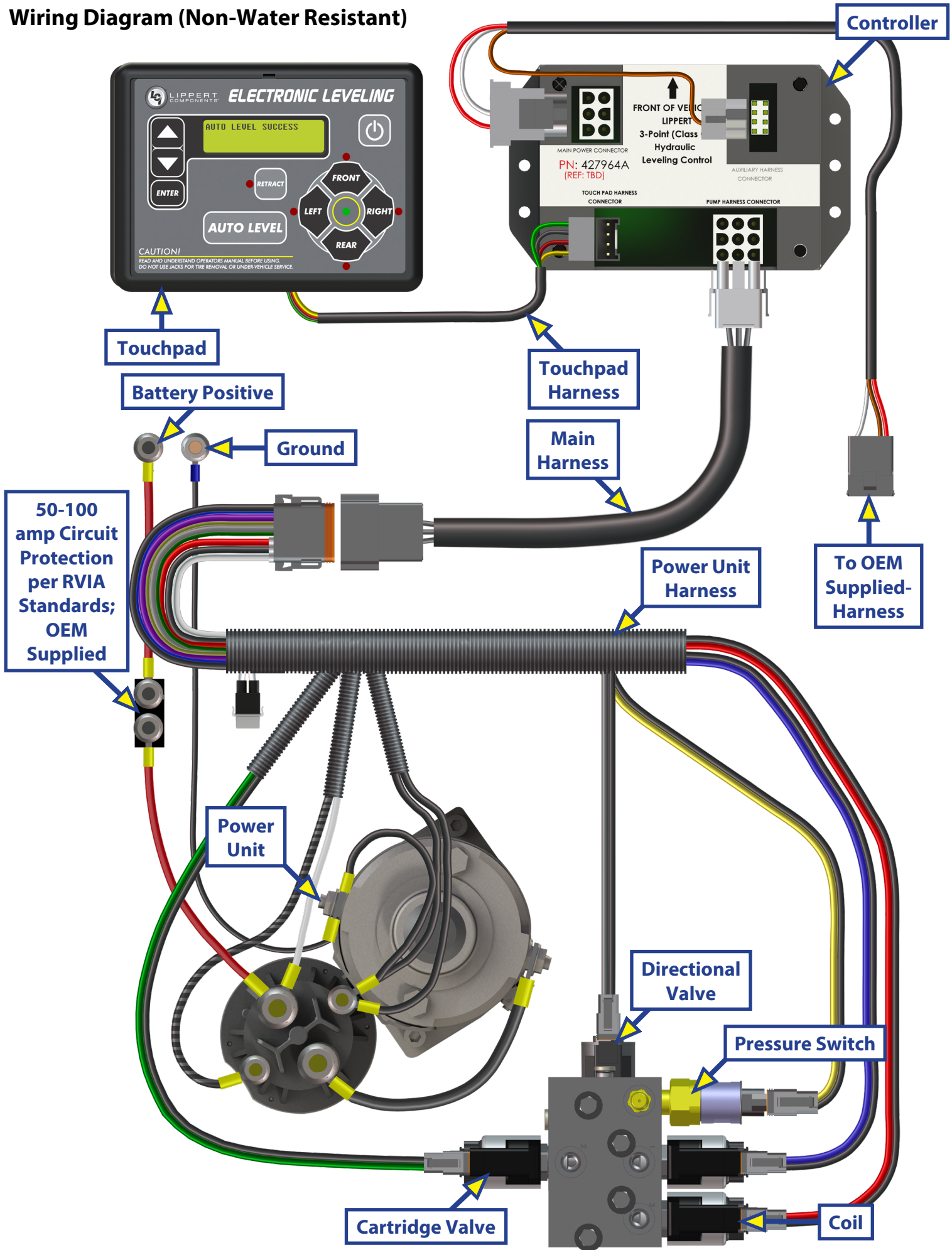

Wiring Diagram (Water Resistant)

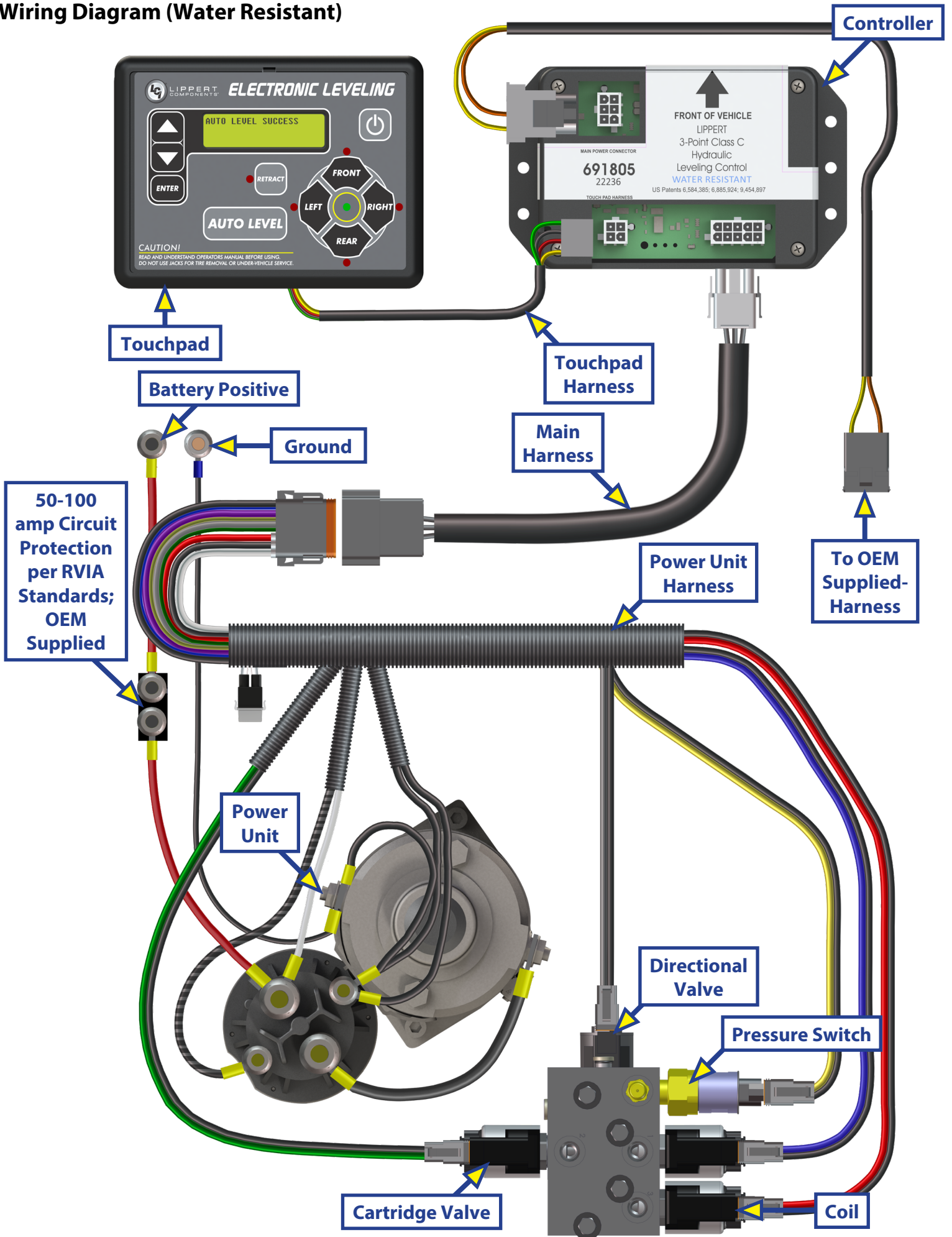

Hydraulic Plumbing Diagram (Aluminum Jacks)

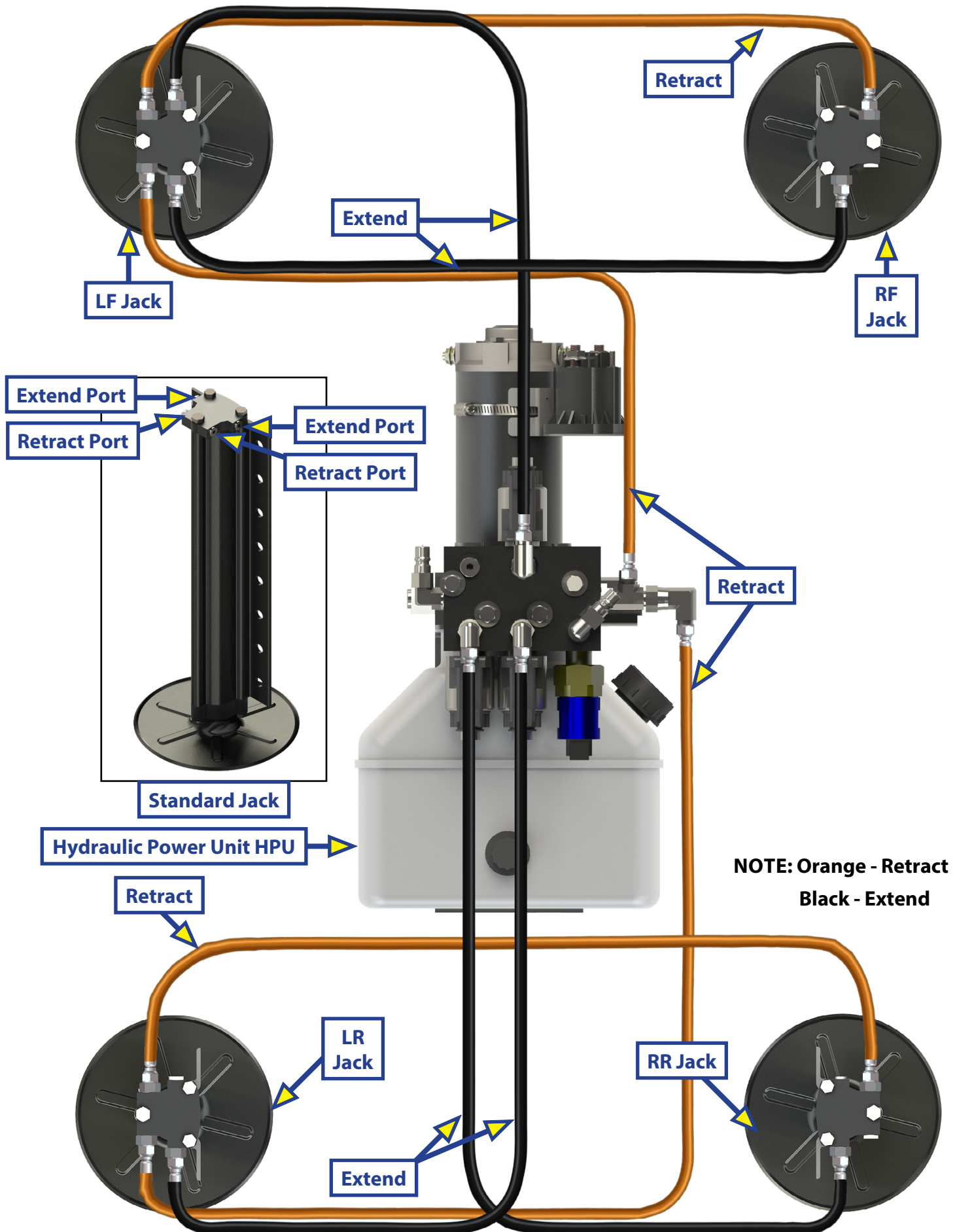

Hydraulic Plumbing Diagram (Steel Jacks)

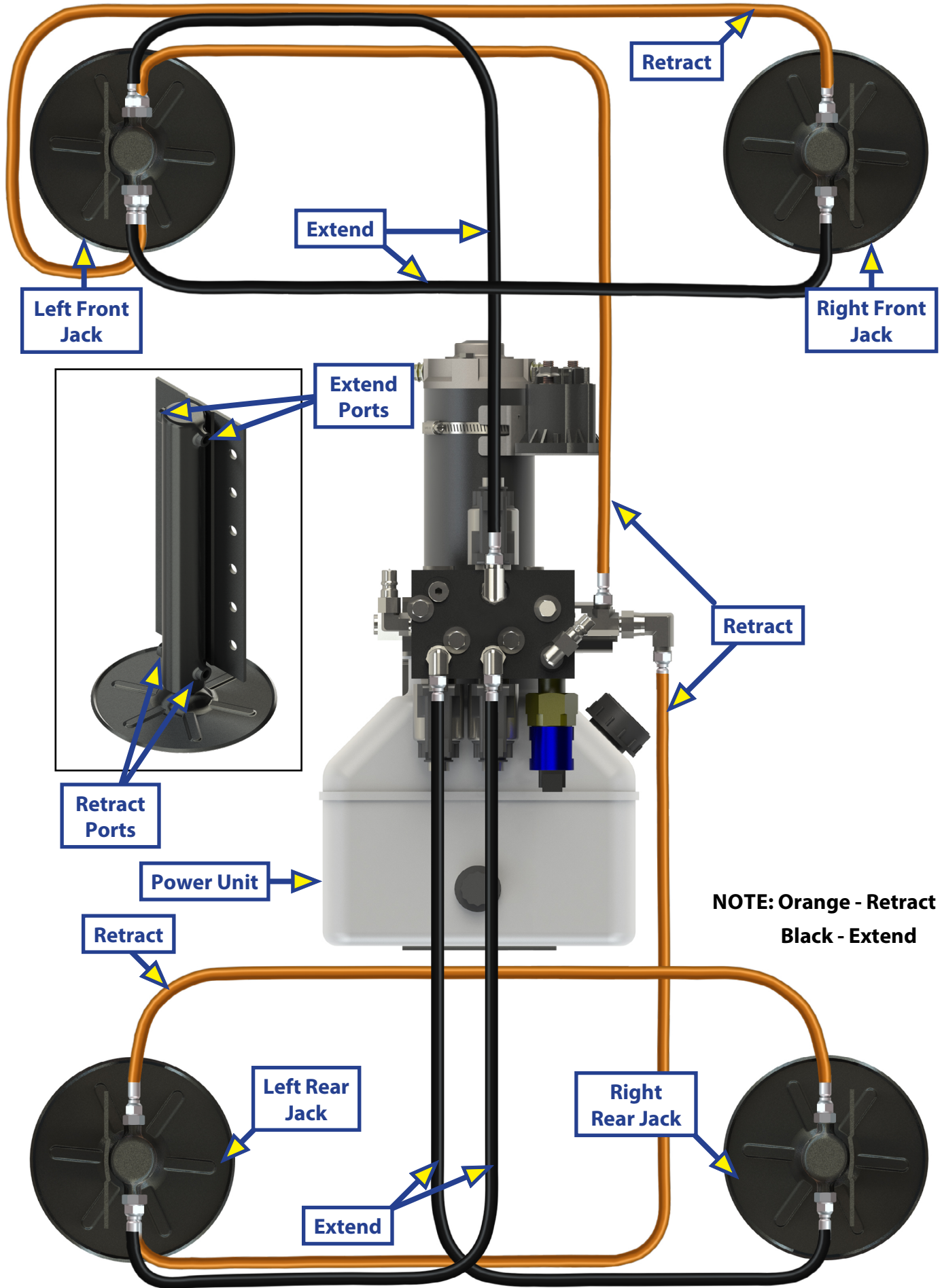



L I P P E R T C O M P O N E N T S[®]

The contents of this manual are proprietary and copyright protected by Lippert Components, Inc. ("LCI"). LCI prohibits the copying or dissemination of portions of this manual unless prior written consent from an authorized LCI representative has been provided. Any unauthorized use shall void any applicable warranty. The information contained in this manual is subject to change without notice and at the sole discretion of LCI.

Revised editions are available for free download from lci1.com.

Please recycle all obsolete materials.

For all concerns or questions, please contact
Lippert Components, Inc.

Ph: (574) 537-8900 | Web: lci1.com | Email: customerservice@lci1.com